

PRESENTS

Double Basses on the Stage Floor

by K Guettler, A Buen and A Askenfelt

Related documents:

[On the interaction between double basses and the stage floor](#)
[An in-depth analysis of the double bass to stage floor contact](#)

akuTEK navigation:

[Home](#)

[Papers](#)

[Title Index](#)

[Stage Acoustics](#)

[Concert Hall Acoustics](#)

DOUBLE BASSES ON THE STAGE FLOOR

Knut Guettler¹, Anders Askenfelt², Anders Buen³

¹*Norwegian Academy of Music, P.O. Box 5190 Majorstuen, Oslo 0302, Norway.*

knut.guettler@nmh.no

²*Dept. of Speech, Music and Hearing, Royal Institute of Technology (KTH), SE-10044 Stockholm, Sweden.*

andersa@speech.kth.se

³*Brekke & Strand akustikk as, Hovfaret 17, 0275 Oslo, Norway.*

Anders.Buen@bs-akustikk.no

Abstract

It is often claimed that a compliant stage floor in contact with the end pin of a double bass will act much like a tabletop in contact with a tuning fork, and assist in radiating the low-frequency sound. On the other hand, it is also claimed with the same conviction that a compliant floor will act as an absorber of airborne sound and thus shorten the low-frequency reverberation time. This pilot study looks at basses' end-pin contact with the floor in terms of impedances and transfer functions in the range 20 to 500 Hz. It was observed that below 100 Hz the transfer ratio is often surprisingly high, in fact noticeably higher than zero dB. The explanation is that while the bass primarily is acting as mass in this range, the floor is often acting as a spring. Data of two double basses, each with two end-pin angles, and a small selection of concert-hall stage floors are discussed in this paper.

INTRODUCTION

Stage floors of the following three concert halls were inspected in terms of impedance and decay times: The Berwald Hall (of Stockholm, Sweden), Oslo Concert Hall, and the Lindeman Hall of the Norwegian Academy of Music (the latter two of Oslo, Norway). The Berwald Hall and Oslo Concert Hall both have podium lifts over a good part of their stage areas. Experiments were performed by means of force hammers and accelerometers. The accelerometers were placed some 3-4 cm from the spots where the hammer was hitting. Positions were chosen (a) on the rigid areas of the floors and (b) on the compliant areas, i.e., for the Berwald Hall and Oslo Concert Hall: on the lifts between joists; for the Lindeman Hall: between joists. (When measuring on the lifts, these were loaded by the person measuring.)

Impedances in the frequency range 20 to 500 Hz was calculated using FFT followed by division in the frequency domain.

Decay times in octave/3 bands were estimated following a procedure where first the force pulse and the response signals were isolated in frequency bands using an 8-pole Chebyshev filter. The resulting signals were so used in a Wiener-filtered deconvolution to retrieve an impulse response with correct phase. Finally, a least-square-fit slope, estimated from a Schroeder curve (backwards energy integration) in the interval 0 to -20 dB, was extrapolated to estimate the decay time, T_{60} , of the different floor sections.

End-pin impedances of two double basses of different sizes were found utilizing two small custom-made adapters where the force hammer could hit in line, or at 30° with respect to the bass end pin, while the accelerometer at all times was mounted in line (See Fig. 1). These angles were chosen to facilitate estimation of pin-to-floor impacts for basses played by a standing or seated player (bass upright 90° or sloped 60°), respectively. The basses were resting on foam rubber with the strings dampened during measurements.

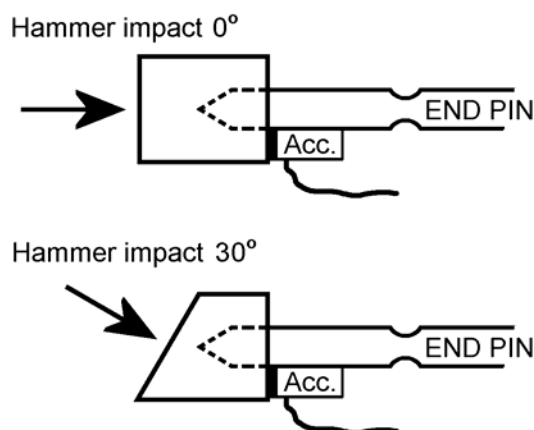

Figure 1: Adapters mounted to the basses' end pins facilitated clean force-hammer impacts at two angles.

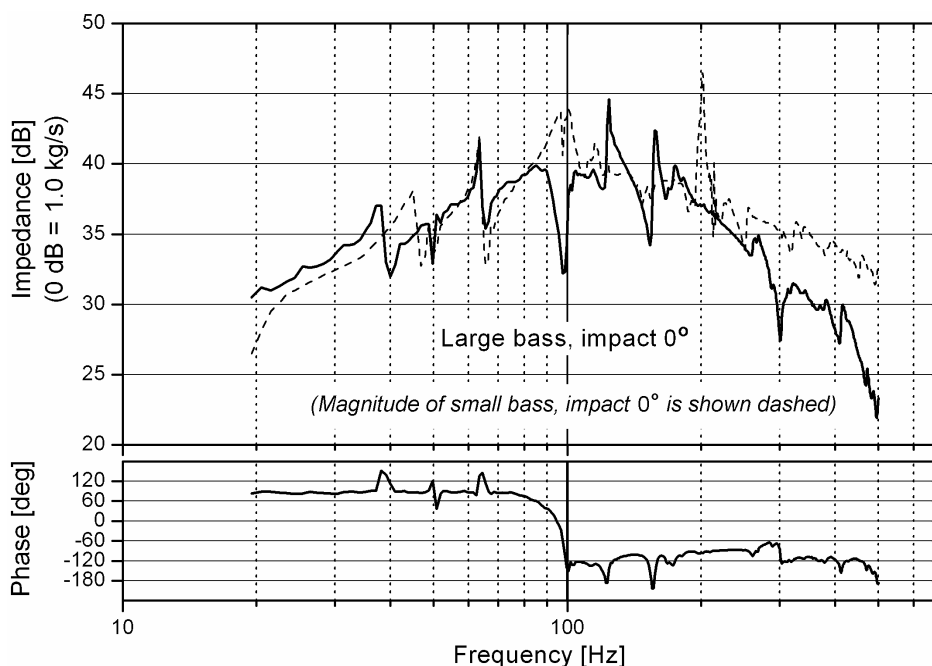

Figure 2: The impedance at end pin of a large double bass. Notice that in the region 20 to 80 Hz the phase is near 90° . That is, the bass is mainly acting as a mass. This feature was found with all combinations of basses and adapters. The impedance magnitude of the small bass is shown superimposed with dashed lines in the upper panel.

THE BASSES

Two medium-quality basses were used for these experiments. Figure 2 shows the impedance of the large bass when impacted at 0° , and superimposed, the impedance magnitude of the smaller bass, same angle. Characteristically, both basses show a trend of impedances rising from 20 Hz to around 100 Hz, where after the impedances decrease. In correspondence with this trend the phase (shown here only for the large bass) remains around $+90^\circ$ (mass) until a shift is seen around 85 Hz. In the range 100 to 500 Hz the phase stays mainly between -90 and -120 degrees. As we shall see later, the best stage floors display impedance curves that mirror these trends both with concern to magnitude and phase.

The tilted basses, or rather angled impacts on end pins moderately pulled out 5 - 6 cm, produced impedance curves quite comparable to the zero-degree impacts, as shown in Figure 3. However, the high end of frequency range where phases were seen laying around $+90^\circ$ was extended from about 85 Hz, for the straight impacts, to well above 100 Hz when impacts were angled.

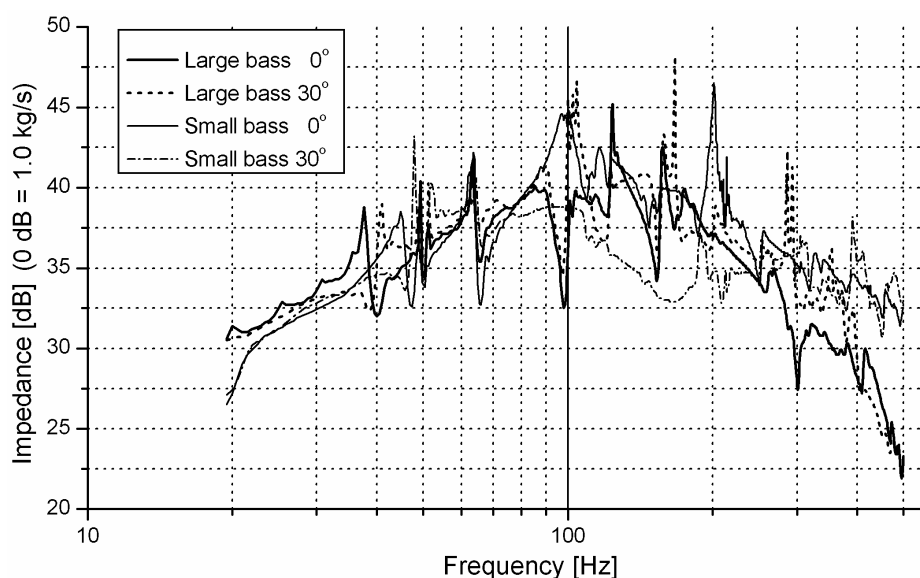

Figure 3: Impedances of the two basses with two impact angles each.

Basses are very poor radiators below their Helmholtz resonance at around 64 Hz. Nevertheless, modern 4-stringed basses are strung down to at least 41 Hz (E_2), and major symphony orchestras all have basses capable of playing C_1 (33 Hz) or B_0 (31 Hz).

THE STAGE FLOORS

The Berwald Hall (BwH), opened 1979, with 1300 audience seats, was designed with the philosophy that the stage floor should be as rigid as possible: The entire wooden floor (Muninga) was glued onto bedrock with hot asphalt. This arrangement was perceived as unsatisfying by the musicians, however, not only for the bassists, but for the entire orchestra. The bassists complained about lack of response and nuances, which made it exhausting to play. After some years (in 1995) it was decided to rebuild parts of the stage floor. Sections, including those where the basses are positioned, were replaced by lifts constructed with wooden tops (Muninga) sealed

to steel plates. No particular damping in the cavity below. This was unanimously perceived as a great improvement.

The Oslo Concert Hall (OCH), opened 1977, with 1404 audience seats in front of the stage and 212 behind, is designed with lifts in the centre and rear of the stage, but not where the basses normally are seated: on the right wing, as seen from the audience. This wing floor should have been built with a small cavity below, but the cavity was dropped for architectural, to our knowledge not acoustical, reasons. Instead the parquet flooring (Merbau) was fastened to plywood, which was glued with hot asphalt to the concrete floor. The paradoxical situation occurred that when the basses moved forward for repertory demanding smaller ensembles, they would enter one of the lifts, and the depth of the bass sound increased. Today, the bass group are normally placed on portable risers when seated on the wings, or on the rear lifts.

The Lindeman Hall (LiH), opened 1988, with 380 to 430 audience seats, part of the Norwegian Academy of Music, is quite successful with respect to supporting a warm double-bass sound, and, to our knowledge, has only been admired for its acoustical properties in the lower frequency range. (On the other hand, it was never the home ground for a professional symphony orchestra on a daily basis...) The stage is smaller than the two mentioned above, but it accommodates well a fully-sized orchestra. The stage floor (22 mm Merbau parquet) is rather compliant, including the joists. Joists, 30 cm apart and resting on thin rubber blocks, hold the floor some 5-6 cm up from the concrete with the cavity in between well damped. There are no lifts on this stage. The reverberation characteristics of LiH are adjustable by means of ceiling sections that can be opened.

The reverberation times of these halls are given in Table 1. As can be seen, the low-frequency reverberation time, T_{60} , of OCH is relatively short, not due to absorption of the stage lifts, but due to thin panelling of the walls. Of course, in order to make a major adjustment in terms of “warmer” sound, a better reflecting wall panel is a prerequisite.

Hall: Frequency Band:	63 Hz	125 Hz	250 Hz	500 Hz	1 kHz	2 kHz	4kHz
BwH	<i>Not available</i>			1.80	<i>Not available</i>		
OCH	1.45	1.50	1.63	1.85	2.05	2.09	1.97
LiH ceiling closed	1.9	2.2	2.1	1.8	1.8	1.7	1.4
LiH ceiling fully opened	2.0	1.6	1.5	1.5	1.5	1.4	1.2

We will start by comparing the most rigid sections of the three halls, that is: the bedrock section of BwH, the wings of OCH, and the joists of LiH (see left panel of Fig. 4): The impedance of the BwH separates itself from the two others with values surpassing 15 000 000 kg/s in range of interest (20 – 100 Hz). This is the “old” part of the floor, where players are normally not positioned anymore. Apart from being much lower, the impedances of OCH and LiH are seen to be falling throughout the whole range of interest; they both have impedance minima in the range 350-450 Hz, and the impedances are springy up to more than 300 Hz. The phase of BwH is falling from a good +100° (mass) at 20 Hz to around -460° (spring) at 50 Hz, where it more or less settles.

A comparison of the most compliant parts of the three halls—i.e., on the lifts between joists of BwH and OCH, and between joists of LiH—show that the most

compliant area now is found at the lifts of BwH, which on the other hand displays springy phase only up to some 40 Hz (see right panel of Fig. 4). OCH and LiH display springy phases up to about 120 and 70 Hz, where they have impedance minima. See also tables 2 through 4 in the appendix, where decay times and averaged impedances, including phase values, are given in oct/3 bands.

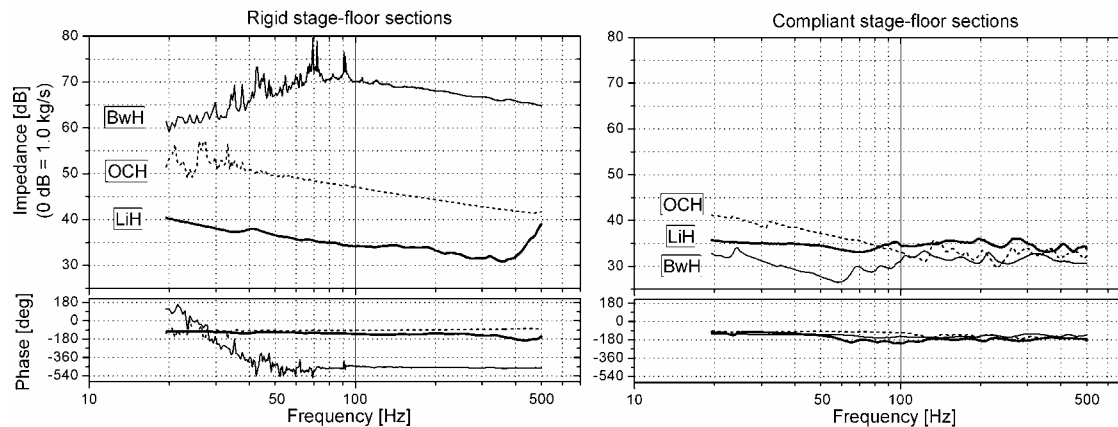

Figure 4: Impedances of rigid (left) and compliant (right) parts of the three stage floors.

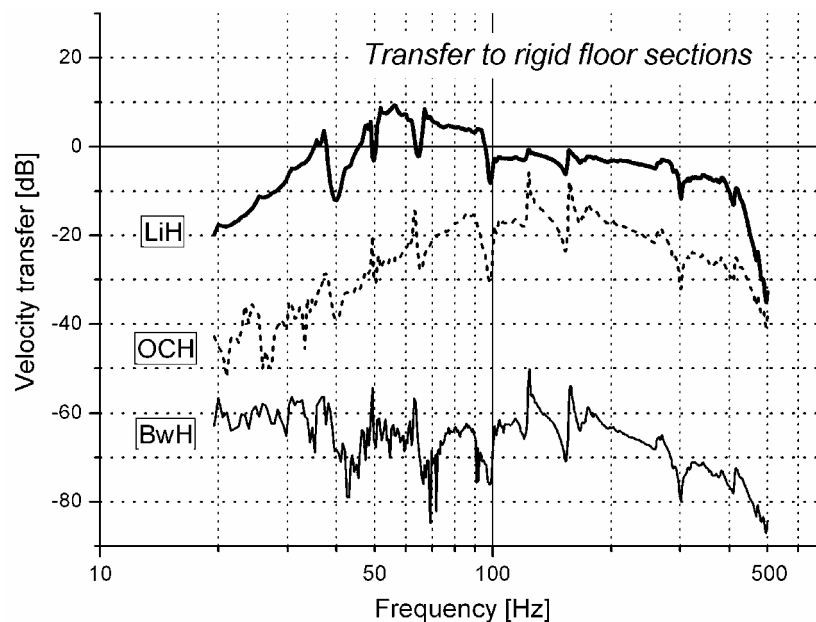

Figure 5: Transfer function of the large bass 0° to the three most rigid sections of the stage floors.

BASS-TO-FLOOR TRANSFER

In the following analysis the simplification is done that transfer is linear between the bass and the stage floor. That is, as if these two parts were tightly coupled (like glued) together. With this assumption the velocity transfer function, $v_{\text{FLOOR}}/v_{\text{BASS}}$, can be calculated simply as $Z_{\text{BASS}}/(Z_{\text{BASS}} + Z_{\text{FLOOR}})$. Figure 5 and 6 show transfer

functions between the large bass upright (0°), and rigid and compliant floors, respectively.

In Fig. 5 it is apparent that for the BwH the transfer from the bass to the rigid floor section is almost nonexistent, while in OCH it is very small. In the LiH, however, due to better matching impedances with opposing phases, the floor is set in quite noticeable vibrations in the interval 35 – 100 Hz, and even up to 300 Hz. In Fig. 6, where the bass has moved from the rigid areas to the stage lifts of BwH and OCH, a major improvement is seen in terms of transfer efficiency. These lifts are undamped, however, so high-peak resonances are experienced in both of them. Such resonances might cause a hollow “empty-barrel” sound if strongly excited. The BwH seems to be supporting the extended range of the double bass (down to 31 Hz) very well with this configuration, but it should be noticed that these lift sections measure a mere 200×140 cm, and can hardly be as efficient low-frequency radiators as the continuous floor of the LiH.

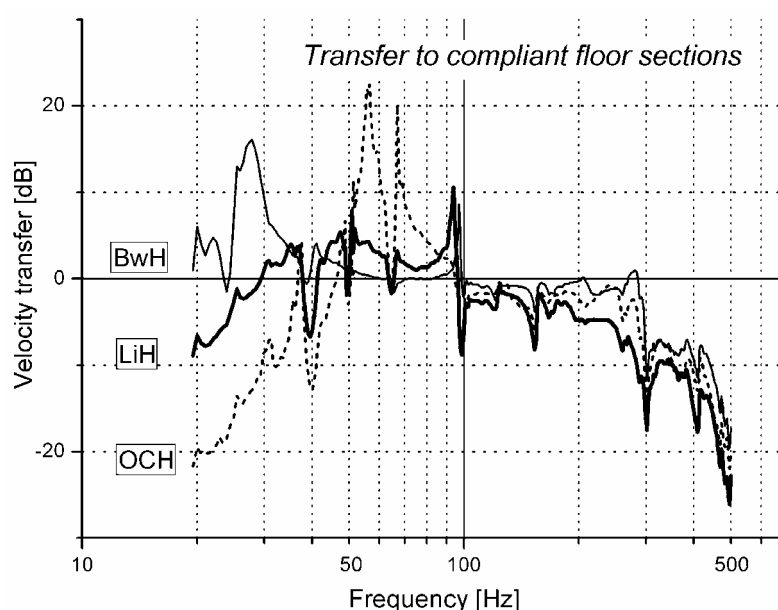

Figure 6: Transfer function of the large bass to the three most compliant sections of the stage floors.

CONCLUSIONS

Acoustical features of stage floors in three concert halls opened during the years 1977 to 1988 have been investigated. The floor sections that were made rigid by fastening the parquet to concrete or bedrock have in practice proven unsatisfactory to the musicians. It is an open question whether this design has ever been successful anywhere.

The first author of this paper has a background as principal double-bass player of the Oslo Philharmonic and the Norwegian Opera, and has performed on numerous stages in many countries, including BwH and OCH. In his opinion rigid stage floors not only gives a colder sound, it also makes the instrument less responsive. In preliminary experiments it was seen that the boundary conditions at the end pin influence the mobility of the bridge, and thus the string/bridge reflections.

When playing in an orchestra the bassists often hear themselves quite poorly, so transfer from one bass to the other through the floor provides an important source of tactile information: With two double basses sharing a riser and only one being played, the bridge vibrations of the passive double bass can be as much as -3 dB compared to the vibrations of the bass being played on [Askenfelt, 1986].

Of the two halls (BwH and OCH) that have stage lifts, the lifts are the preferred floor sections for the bass players. However, these areas do not appear to have been constructed with the same care as the rest of the floor, since the damping is seen to be uneven, resulting in pronounced resonances. Nonetheless, these sections show impedances that facilitate very efficient transfer of low-frequency vibrations from double basses through their end pins, and thus ensure greatly improved radiation in the lowest range (30 to 100 Hz) of these instruments. In general it appears that the impedances of a normal floor with parquet on joists (like for instance the lab floor of KTH) are likely to combine well with those of the bass. However, for a stage floor it seems preferable that its major resonance is adequately damped and lies well above 100 Hz in order to ensure a steady impedance phase not too far from -90° and even transfer in the range 30 to 100 Hz. Damping also influences the response time of the floor, and thus the latency of the radiated bass sound.

To the discussion on to what extent a pliant podium will absorb energy in the low-frequency range the following example calculations may shed some light: For a rigid floor the absorption coefficient in the 63 Hz band may be $\alpha_{\text{RIG}} = 0.04$, while for a pliant floor $\alpha_{\text{PLI}} = 0.25$. Given a stage floor of 150 m^2 , this makes absorption areas of 6.0 and 37.5 m^2 , respectively. Imagine two symphonic halls of 8000 and 24000 cubic meters, both with stage floors of 150 m^2 . Using Sabine's equation ($0.163 \text{ s m}^{-1} \times \text{volume} / T_{60} = \text{Sabine m}^2$) we get for a hall with rigid floor and reverberation time $T_{60\text{RIG}} = 2.0 \text{ s}$, absorption areas of 652 and 1956 m^2 Sabine, respectively. To recalculate T_{60} for the pliant stage floor in the 63 Hz band we set: $T_{60\text{PLI}} = 0.163 \text{ s m}^{-1} \times \text{volume} / (\text{absorption area} - 6.0 \text{ m}^2 + 37.5 \text{ m}^2)$, which gives 1.91 and 1.97 s , respectively. That is a reduction in reverberation time of a mere 92 ms for the small, and 32 ms for the large hall, respectively. These differences are hardly audible. What should be audible, however, is the increase of energy radiated in the same frequency band when the low-pitched instruments are in touch with the compliant stage floor.

REFERENCE

A. Askenfelt (1986). "Stage floors and risers - supporting resonant bodies or sound traps?" *Acoustics for choir and orchestra*. Ed.: S. Tärnström. The Royal Swedish Academy of Music, Stockholm, Sweden. **52**, 43 - 61.

APPENDIX

The following three tables provide information on impedance and damping of the floors, averaged in oct/3 bands. Where a decay-time value is marked with asterisk, the sound/noise level has been too small for an estimation of RT_{60} based on the 0 to -20 dB decay, so EDT based on the 0 to -10 dB decay was used instead.

Freq. band [Hz]	Decay _{-60dB} [ms]		Loss factor		Impedance magn. [kg/s]		phase [degrees]	
20	N O T A V A I L A B L E	748	N O T A V A I L A B L E	.149	1340511	1711	120	-109
25		228		.387	1606738	1888	-14	-112
31		131		.535	2850221	1199	-238	-107
40		194		.287	6333642	868	-417	-119
50		222		.199	7405605	608	-440	-137
63		236		.149	15405451	658	-498	172
80		256		.109	14717307	875	-465	168
100		280		.079	12659163	1324	-447	155
125		108		.162	9116690	1805	-457	178
160		112		.124	7650873	1466	-459	-175
200		80		.138	6558045	1467	-459	-178
250		70		.125	5228238	1244	-460	-177
320		31		.223	4412397	1749	-463	-176
400		21		.258	3831169	1321	-465	-162
500		10		.438	3273417	1155	-463	-169

Freq. band [Hz]	Decay _{-60dB} [ms]		Loss factor		Impedance magn. [kg/s]		phase [degrees]	
20	N O T A V A I L A B L E	296*	N O T A V A I L A B L E	.376*	224492	12551	-119	-98
25		169*		.523*	243329	10587	-115	-100
31		128*		.547*	187946	8405	-111	-105
40		107*		.519*	125092	7068	-98	-100
50		81		.542	92465	5290	-98	-98
63		67		.522	77416	3974	-96	-101
80		194		.144	62087	2910	-95	-103
100		251		.088	51047	2005	-94	-112
125		215		.082	40498	2198	-92	-151
160		131		.106	32743	2182	-92	-131
200		115		.096	27065	1679	-90	-139
250		108		.081	22044	1657	-87	-170
320		97		.072	18250	2032	-84	-161
400		80		.069	15369	1933	-80	-160
500		65		.067	14097	1790	-79	-169

Freq. band [Hz]	Decay _{-60dB} [ms]		Loss factor		Impedance magn. [kg/s]		phase [degrees]	
20	215	356	.518	.313	9950	3554	-105	-124
25	197	255	.449	.347	7951	3293	-106	-126
31	203	189	.346	.371	6016	3155	-111	-129
40	144	140	.388	.397	5850	3090	-120	-129
50	85	110	.519	.402	4680	2785	-112	-128
63	69	55	.511	.639	3706	2208	-118	-135
80	52	87	.537	.320	3141	2434	-122	-157
100	34	105	.657	.211	2667	2985	-129	-151
125	36	54	.494	.327	2632	2995	-136	-156
160	34	68	.409	.204	2523	3487	-132	-152
200	30	72	.366	.153	2165	3465	-126	-142
250	35	38	.248	.229	1653	3274	-130	-146
320	23	49	.304	.142	1430	2754	-144	-125
400	27	48	.201	.115	1795	2472	178	-140
500	25	48	.172	.091	5085	2521	-176	-141

* Based on the Early-Decay-Time slope (0 to -10 dB).